

METRIC

MIL-HDBK-2051(SH)  
22 May 1996  
SUPERSEDING  
MIL-STD-2051(SH)  
21 April 1994

MILITARY HANDBOOK  
FIBER OPTIC SHIPBOARD  
CABLE TOPOLOGY DESIGN GUIDANCE



AMSC N/A

AREA GDRQ

DISTRIBUTION STATEMENT A . Approved for public release; distribution is unlimited.

MIL-HDBK-2051(SH)

FOREWORD

1. This military handbook is approved for use by all Departments and Agencies of the Department of Defense.
2. Beneficial comments (recommendations, additions, deletions) and any pertinent data which may be of use in improving this document should be addressed to: Commander, Naval Sea Systems Command, SEA 03K12, 2531 Jefferson Davis Highway, Arlington, VA 22242-5160 by using the self-addressed Standardization Document Improvement Proposal (DD Form 1426) appearing at the end of this document or by letter.
3. This document provides guidance for the design of fiber optic cable topologies for shipboard applications.

## MIL-HDBK-2051(SH)

## CONTENTS

<u>PARAGRAPH</u>	<u>PAGE</u>
1. SCOPE	1
2. APPLICABLE DOCUMENTS	2
2.1 Government documents	2
2.2 Non-Government publications	3
2.3 Order of precedence	3
3. DEFINITIONS	4
3.1 Acronyms	4
3.2 Definitions	4
3.2.1 Allocated and used fiber	4
3.2.2 Allocated and not used fiber	4
3.2.3 Alternate channel	4
3.2.4 End user equipment	4
3.2.5 Fiber optic cable plant	4
3.2.6 Growth fiber	4
3.2.7 Intermediate interconnection box	4
3.2.8 Local cable	4
3.2.9 Nonadjacent trunk links	4
3.2.10 Non redundant channel	4
3.2.11 Normal channel	4
3.2.12 Outlet	4
3.2.13 Redundant fiber	5
3.2.14 Redundant trunk	5
3.2.15 Service area	5
3.2.16 Spare fiber (mainenance spare fiber)	5
3.2.17 System spare fiber	5
3.2.18 Trunk	5
3.2.19 Trunk cable	5
3.2.20 Unallocated fiber	5
3.2.21 Unused fiber	5
4. GENERAL	6
4.1 Fiber optic cable topology concept	6
4.1.1 FOCT characteristics	6
4.1.2 Cable	6
4.2 Design process	7
4.2.1 General process	7
4.2.2 FOCT configuration	7
4.3 Design methodology	8
4.3.1 Conceptual design	8
4.3.2 Preliminary design	8
4.3.3 Detailed design	10
4.4 Design documentation	11
5. DESIGN PROCESS	12
5.1 Design process	12
5.1.1 FOCT design development	12
5.2 Conceptual design	12
5.2.1 Conceptual design process	12
5.2.2 Conceptual design summary	13
5.3 Preliminary design	13
5.3.1 Preliminary design process	13
5.3.2 FOCT block diagram and isometric cabling diagram	20

## MIL-HDBK-2051 (SH)

## CONTENTS

<u>PARAGRAPH</u>		<u>PAGE</u>
5.4	Detailed design	20
5.4.1	Detailed design process	20
5.4.2	Detailed design documentation	24
6.	NOTES	25
6.1	Intended use	25
6.2	Subject term (key word) listing	25
 <u>FIGURE</u>		
1	Typical fiber optic cable interconnects	7
2	FOCT design process	9
3	Intermediate interconnection box	17
4	Usage of an intermediate interconnection box	17
5	Local cables for normal and alternate channels	19
6	Patch panel configuration	21
7	Splice tray holder configuration	21
8	Slice tray configuration	22
9	Typical end user equipment terminations	23
10	Typical end user equipment rack terminations	23

MIL-HDBK-2051(SH)

1. SCOPE

1.1 Scope. This handbook contains suggested design rules for defining a fiber optic cable topology. In addition, this document describes a suggested approach for developing and designing a fiber optic cable topology (FOCT) for a Naval platform and also identifies the applicable fiber optic component specifications. This handbook is primarily intended for use by the fiber optic cable topology design engineer, but provides useful information to a systems design engineer as well.

## MIL-HDBK-2051(SH)

## 2. APPLICABLE DOCUMENTS

2.1 Government documents .

2.1.1 Specifications and standards . The following specifications and standards form a part of this document to the extent specified herein. Unless otherwise specified, the issues of these documents are those listed in the issue of the Department of Defense Index of Specifications and Standards (DODISS) and supplement thereto, cited in the solicitation (see 6.2).

## SPECIFICATIONS

## MILITARY

- MIL-S-24623 - Splice, Fiber Optic Cable, General Specification For (Metric).
- MIL-S-24623/4 - Splice, Fiber Optic, Housing, Rotary Mechanical, Fiber.
- MIL-I-24728 - Interconnection Box, Fiber Optic, Metric, General Specification For.
- MIL-C-28876 - Connectors, Fiber Optic, Circular, Plug and Receptacle Styles, Multiple Removable Termini, General Specification For.
- MIL-T-29504 - Termini, Fiber Optic Connector, Removable, General Specification For.
- MIL-T-29504/14 - Termini, Fiber Optic, Connector, Removable, Environment Resisting, Class 5, Type II, Style A, Pin Terminus, Front Release, Ceramic Guide Bushing (For Mil-C-28876 Connectors).
- MIL-T-31000 - Technical Data Packages, General Specification For.
- MIL-F-49291 - Fiber, Optical, General Specification For (Metric).
- MIL-F-49291/6 - Fiber, Optical, Type I, Class I, Size IV, Composition A, Wavelength B, Radiation Hardened (Metric).
- MIL-F-49291/7 - Fiber, Optical, Type II, Class 5, Size II, Composition A, Wavelength D, Radiation Hardened (Metric).
- MIL-C-83522 - Connectors, Fiber Optic, Single Terminus, General Specification For.
- MIL-C-83522/16 - Connector, Fiber Optic, Single Terminus, Plug, Bayonet Coupling (ST Style), 2.5 Millimeters Diameter Ferrule, Epoxy.
- MIL-C-85045 - Cables, Fiber Optic, (Metric), General Specification For.

MIL-HDBK-2051(SH)

STANDARDS

MILITARY

MIL-STD-2042 - Fiber Optic Cable Topology Installation Standard  
Methods for Naval Ships.

MIL-STD-2052 - Fiber Optic Systems Design.

(Unless otherwise indicated, copies of federal and military specifications, standards, and handbooks are available from the Standardization Documents Order Desk, BLDG. 4D, 700 Robbins Avenue, Philadelphia, PA 19111-5094.)

2.2 Non-Government publications . The following documents form a part of this document to the extent specified herein. Unless otherwise specified, the issues of the documents which are DOD adopted are those listed in the issue of the DODISS cited in the solicitation. Unless otherwise specified, the issues of documents not listed in the DODISS are the issues of the documents cited in the solicitation (see 6.2).

ELECTRONICS INDUSTRY ASSOCIATION/TELECOMMUNICATIONS INDUSTRY ASSOCIATION

EIA/TIA-440 - Fiber Optic Terminology.

(Application for copies should be addressed to Global Engineering Documents, 1990 M Street NW, Suite 400, Washington, DC 20036.)

2.3 Order of precedence . In the event of conflict between the text of this document and the references cited herein, the text of this document takes precedence. Nothing in this document, however, supersedes applicable laws and regulations unless a specific exemption has been obtained.

## MIL-HDBK-2051(SH)

## 3. DEFINITIONS

3.1 Acronyms . The acronyms used in this handbook are defined as follows:

- a. FOCP - Fiber Optic Cable Plant
- b. ECP - Engineering Change Proposal
- c. FOCT - Fiber Optic Cable Topology
- d. NRC - Non Redundant Channel

3.2 Definitions . Definitions for general fiber optics terms used in this handbook are in accordance with EIA/TIA-440. Definitions for other terms as they are used in this handbook are given in the following paragraphs.

3.2.1 Allocated and used fiber . An allocated and used fiber is a fiber that is designated and required for use for a particular system link, and is being used to transmit information. Allocated and used fibers include fibers used for normal channels, fibers for alternate channels, and fibers for non redundant channels.

3.2.2 Allocated and not used fiber . An allocated and not used fiber is a fiber that is designated for use for a particular system, but is not being used to transmit information. Allocated and not used fibers include fibers allocated as system spare fibers, system growth fibers, and system redundant fibers.

3.2.3 Alternate channel . An alternate channel is the allocated and used active backup link for a normal channel.

3.2.4 End user equipment . End user equipment refers to any cabinet, case, panel, or device that contains components that are either the origin or destination of an optical signal.

3.2.5 Fiber optic cable plant . The fiber optic cable plant consists of the fiber optic interconnection boxes, trunk cables and the connectors and splices used to terminate the trunk cables.

3.2.6 Growth fiber . An unallocated fiber intended for later use in the installation of fiber optic systems after initial ship construction.

3.2.7 Intermediate interconnection box . An interconnection box in which two trunk fibers are interconnected.

3.2.8 Local cable . A local cable is a fiber optic cable that provides a continuous optical path between an interconnection box (or outlet) and an end user equipment or between an interconnection box and an outlet, and is typically not run through the main cableways.

3.2.9 Nonadjacent trunk links . Links in a network which do not connect to a common node.

3.2.10 Non redundant channel (NRC) . A non redundant channel is any allocated and used active link that has no system required backup link.

3.2.11 Normal channel . A normal channel is an allocated and used active link between end user equipment which has a designated active backup link.

3.2.12 Outlet . An outlet is a small termination box used to break out a local cable from an interconnection box to one or more equipments within a compartment.

MIL-HDBK-2051(SH)

3.2.13 Redundant fiber . A redundant fiber is a fiber within the FOCT which is functionally redundant to another fiber. Switching to the redundant fiber requires manual reconfiguration.

3.2.14 Redundant trunk . A redundant trunk is a second cable trunk between two interconnection boxes that requires different routing from the primary trunk.

3.2.15 Service area . The compartment or group of compartments that accesses the fiber optic cable plant via a shared interconnection box.

3.2.16 Spare fiber (maintenance spare fiber) . A fiber that is not allocated for use by any system, but is reserved for use as a maintenance spare in the case of damage to an allocated fiber within a trunk or local cable that penetrates a deck or bulkhead.

3.2.17 System spare fiber . A fiber that is reserved for use as a maintenance spare for a particular system in the case of damage to an allocated and used system fiber within the cable.

3.2.18 Trunk . A trunk is a set of trunk cables that run along the same path between two interconnection boxes.

3.2.19 Trunk cable . A trunk cable is a fiber optic cable that provides a continuous optical path between interconnection boxes. Typically, trunk cables are run in the main cableways and have higher fiber counts per cable than local cables.

3.2.20 Unallocated fiber . An unallocated fiber is a fiber that is not designated for use for any system, but is required as part of the fiber optic cable plant. Unallocated fibers include spare fibers and growth fibers.

3.2.21 Unused fiber . An unused fiber is a fiber that is not designated for use by any system and not required as part of the FOCT. Unused fibers occur within the FOCT when the required systems fibers are less than the number of fiber available within a standard cable size.

## MIL-HDBK-2051(SH)

## 4. GENERAL

4.1 Fiber optic cable topology (FOCT) concept . The concept of the FOCT is that of a shared resource. It is an integrated fiber optic cabling system installed during ship construction (or major overhaul) that supports all shipboard intercompartment fiber optic interconnect requirements. This includes growth, expansion and reconfiguration throughout the life of the ship. A fiber optic cable plant (FOCP) is laid in the ship interconnecting key locations. End user equipments connect into this FOCP rather than laying individual cables between the equipments. The FOCP is configured so that point-to-point links or networks are easily accommodated. The FOCP and FOCT are most efficient when there are many different systems requiring fiber optic interconnects located throughout the ship.

4.1.1 FOCT characteristics . The FOCT consists of fibers and cables, splices, connectors and interconnection boxes. Because fibers and cables are light-weight and small, unused fibers may be installed during ship construction to provide available fibers when fiber optic systems are installed after the ship has been delivered to the Navy. Additionally, redundant fibers may be installed so that links that are lost due to battle damage can be restored by reconfiguring around the damaged cable section.

4.1.2 Cable . An end user equipment accesses the FOCP by running a cable from the equipment to an interconnection box. This cable is called a local cable. Interconnection boxes are connected together with cables called trunk cables. The local cables are interconnected with the trunk cables to provide a complete link between end user equipments (see figure 1). The set of complete links defines the FOCT for a particular platform.

## MIL-HDBK-2051 (SH)

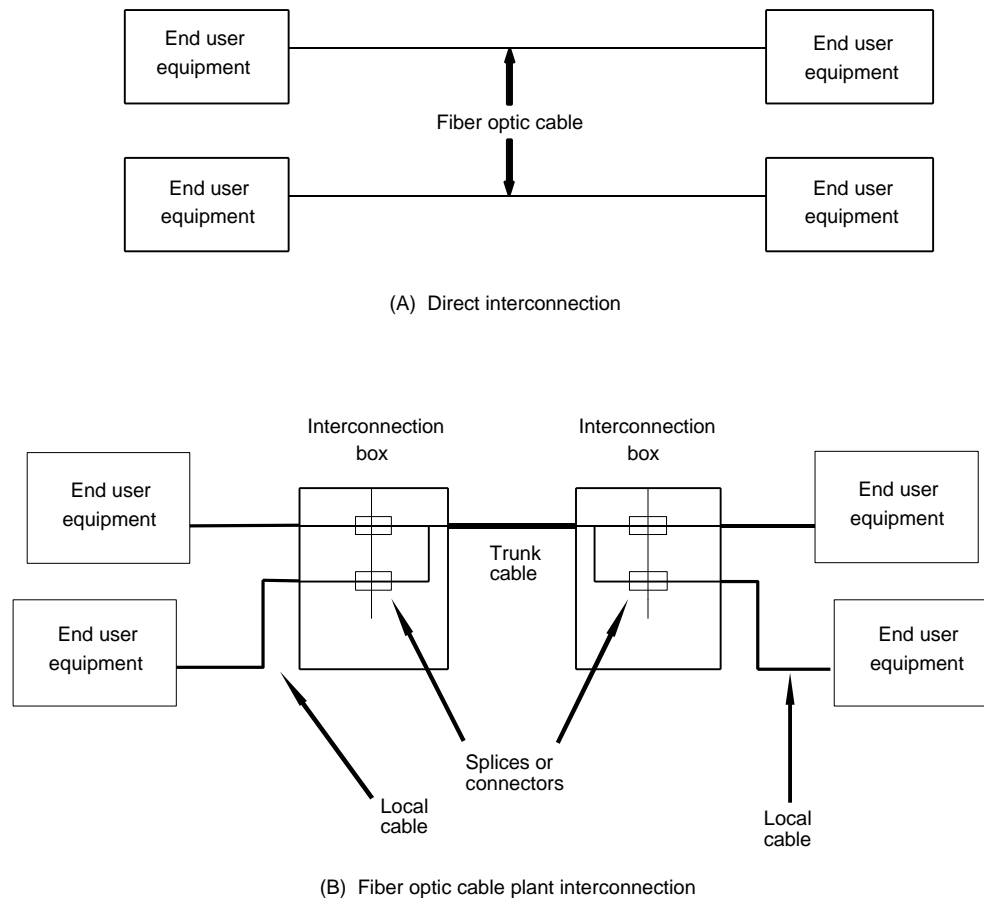

**Figure 1. Typical fiber optic cable interconnects.**

**4.2 Design process .** This handbook identifies a design process for designing a FOCT. This process is divided into a three phase approach which corresponds to the ship design process. The input information in each phase and the design recommendations herein are used to optimize the FOCP and FOCT configuration for the intended platform.

**4.2.1 General process .** The general process (see figure 2) starts with a review of the ship specification and ship configuration for the intended platform to determine general requirements for the FOCT. Specifications for all systems using fiber optics are also reviewed to determine specific requirements; fiber and cable type, termination requirements, fiber optic performance requirements; as well as additional general requirements that will shape the configuration of the FOCP and FOCT.

**4.2.2 FOCT configuration .** After all the input requirements are determined, a FOCT configuration may be developed. The FOCT configuration for the platform is married with the detailed ship configuration to generate the detailed design information; fiber run lists, cable routing diagrams, interconnection box configuration drawings, and detailed parts lists. This entire package, the FOCT system drawings and the detailed design information, defines the FOCT for the host platform.

## MIL-HDBK-2051(SH)

4.3 Design methodology . The FOCT design process involves a three phase approach: conceptual, preliminary and detailed (see figure 2). As each phase is completed the output from that phase becomes part of the input to the next phase. Each design phase may be repeated as the ship system and ship design information and requirements are modified. An optimal configuration with the appropriate documentation necessary to specify and install a FOCT is the final output of the detailed design phase.

4.3.1 Conceptual design . The conceptual design phase is used to develop an initial FOCP configuration. The inputs to this design phase are:

- a. Ship specification
- b. Ship configuration information
- c. System specifications
- d. Conceptual design guidelines (see 5.2.1)

These inputs can be used to determine the general location of interconnection boxes and the compartments that the interconnection box will service (service areas). General interconnections between interconnection boxes can be identified, determining the trunk requirements for the FOCP. A FOCP block diagram can be developed and is used as an input in the preliminary design phase. If required, this information may also be depicted on an isometric cabling diagram. Typical outputs of the conceptual design phase are:

- a. Service area definition
- b. Block diagram showing
  - Interconnection box location (general)
  - Interconnection box service area
  - Trunks between interconnection boxes
- c. Isometric cabling diagram showing
  - Interconnection box location (general)
  - Trunks between interconnection boxes

4.3.2 Preliminary design . The preliminary design builds on the conceptual design providing more details on the FOCT configuration. Inputs used to develop the preliminary design are:

- a. Conceptual design block diagram
- b. Conceptual isometric cabling diagram
- c. Detailed system requirements
- d. Preliminary design guidelines (see 5.3.1)
- e. Ship configuration information
- f. Ship specification

The system requirements can be reviewed to determine the following FOCT requirements:

- a. Type of fiber
- b. Number of fibers required
- c. Type of cable for local cables
- d. Type of termination to be used
- e. Link loss requirements

4.3.2.1 System equipment location . The location of system equipments can be determined from the ship configuration drawings.

MIL-HDBK-2051(SH)

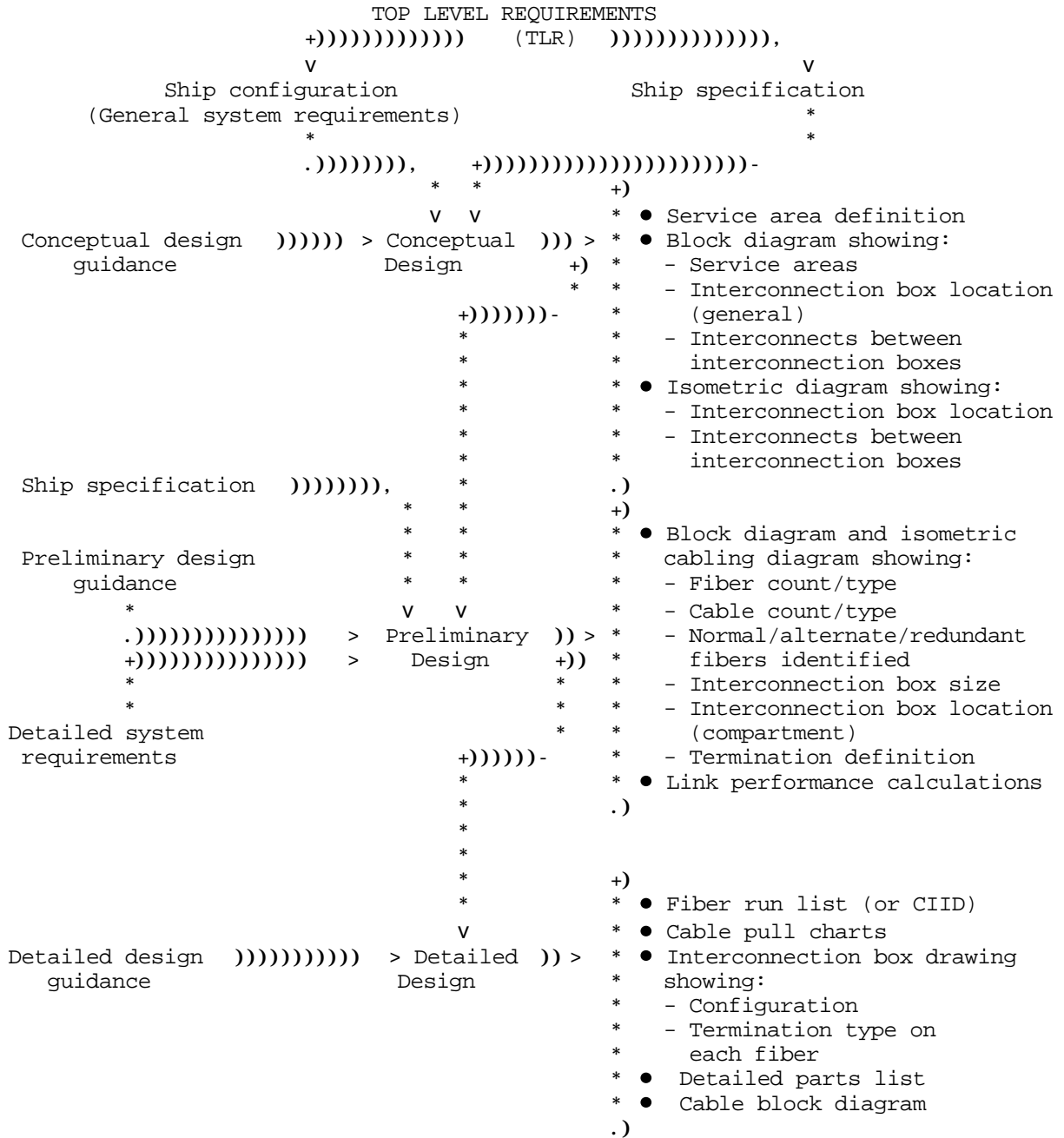

Figure 2. FOCT design process .

4.3.2.2 FOCT block diagram and isometric cabling diagram . The information from the ship configuration drawing can also be used to determine the size and location of the interconnection boxes and the type of interconnection modules used as well as to identify the trunk cable capacities and preliminary FOCT configuration. All of this information can be used to develop a FOCT block diagram and isometric cabling diagram which show:

## MIL-HDBK-2051(SH)

- a. Interconnection box service areas
- b. Fiber count/types
- c. Cable count/types
- d. Identification of the fiber function
- e. Interconnection boxes
  - size
  - Location (compartment)
- f. Termination types

4.3.2.3 FOCT configuration control . The block diagram and isometric cabling diagram developed during this phase should be the final design configuration of the FOCT and should be placed under configuration control at this point.

4.3.2.4 Link budgets . A link loss budget should be calculated for each link in the FOCT (unless already calculated by the system designer) to ensure that the system performance requirements are met for each FOCT user. If the system performance requirements can not be met, the FOCT configuration should be changed (that is, connectors changed to splices, intermediate interconnection boxes eliminated, and so forth) to ensure all links meet the system performance requirements. MIL-STD-2052 should be used to compute link loss budgets.

4.3.2.5 Fiber optic cable topology . Together the ship specification and the FOCT block diagram completely define the FOCT. These documents are used as input to the detailed design phase of the FOCT design. Ideally, the FOCT preliminary design phase should be completed in time so that the FOCT detail design is done in conjunction with the ship detail design.

4.3.3 Detailed design . This is the final phase in the development of a shipboard cable plant design. The documentation developed in this phase should provide all the necessary information for the ship builder to procure the components and integrate them into the FOCT. The inputs used to develop this final documentation package are:

- a. FOCT preliminary design block diagram
- b. Ship specification
- c. Detailed ship construction drawings
- d. Fiber optic component specifications

4.3.3.1 Design process and products . The detailed design process takes the preliminary FOCT block diagram and merges it into the ship construction drawings providing detailed information on the specific FOCT components to be used and their exact location on the ship. The exact location of the interconnection boxes within the compartments should be identified along with the location of the cableways that cables will be routed in. Fiber run lists, or cable installation interconnection drawings (CIIDs), and configuration drawings showing the terminations within each interconnection box should be developed providing the end-to-end connection requirements between system equipments. Finally, a detailed parts list showing all the components in the FOCT should be generated. The outputs of the detailed design phase are:

MIL-HDBK-2051(SH)

- a. System drawing showing:
  - the number of trunks between interconnection boxes
  - the number of cables in each trunk
  - the type and number of each fibers in each cable
  - routing restriction on trunk and local cables
  - terminations on local cables at equipment interface
- b. Fiber run list (this information may be included in the FOCT configuration, interconnection box configuration, and cable block diagrams or CIIDs.)
- c. Cable pull charts
- d. Interconnection box configuration drawing showing:
  - termination type on each fiber
  - configuration of terminations in interconnection modules
- e. Detailed parts list

4.4 Design documentation . All FOCT design documentation should be developed using MIL-T-31000 and MIL-STD-100 as guides.

## MIL-HDBK-2051(SH)

## 5. DESIGN PROCESS

5.1 Design process . The design process outlined in 4.3 is tailored to the ship design process and schedule. The FOCT design is based on information from the ship specifications and on detailed ship configuration information. At the end of each phase of the design process, the FOCT design should be placed under configuration control and then integrated into the total ship design package. The FOCT design should be done in conjunction with the ship design so that modifications to the ship contract to incorporate the FOCT are not required.

5.1.1 FOCT design development . The following sections identify the information that is required at each phase in the development of the FOCT design. The requirements from the ship and system specifications are combined with FOCT design guidance to develop the optimal configuration of the FOCT for the specific platform on which it is to be installed.

5.2 Conceptual design . The first phase in developing a FOCT is the conceptual design. Ship and system specifications and ship configuration drawings are reviewed to determine ship and system configurations and requirements. From these requirements the initial FOCT configuration is developed. This initial design shows the location and the approximate number of interconnection boxes as well as identifying interconnecting trunks between interconnection boxes.

5.2.1 Conceptual design process . In order to optimize the FOCT configuration, information on the end user equipment that will interface to the cable plant is analyzed to develop the following items:

- a. Service area definitions
- b. Trunks required between interconnection boxes

5.2.1.1 Service area definition . A service area is a set of compartments that are grouped together to share the same interconnection box. Service areas are determined by identifying all compartments on the ship that require access to the FOCT and then grouping the compartments together based on location and the number of systems using the FOCT within a local area. The interconnection boxes are then preliminarily located within the service areas. If possible, a service area should contain compartments from no more than one or two watertight zones within the ship.

5.2.1.2 Trunks between interconnection boxes . Once service areas are defined and preliminary interconnection box locations are chosen, the interconnection requirements between interconnection boxes are identified. For the conceptual design it is sufficient to identify a requirement for an interconnection without specifying the total number of fibers required in that interconnection.

5.2.1.2.1 Interconnection requirements . The interconnection requirements are determined from the system specifications, system drawings, and ship configuration drawings. The system specification or system drawings should identify the interconnection requirements between system equipments while the ship configuration drawings should identify the location of those equipments. This information is used to identify the trunks required between interconnection boxes. Local cables are routed from the system equipment to the interconnection box in that equipment's service area. The total interconnection requirements between equipments determines the trunks required between interconnection boxes.

## MIL-HDBK-2051(SH)

5.2.2 Conceptual design summary . The output of the conceptual phase of the design process is a block diagram and isometric cabling diagrams showing the conceptual configuration of the cable plant. The drawings should show the interconnection box service areas, preliminary interconnection box locations and the interconnection requirements between service areas. As a minimum, there should be one interconnection box for each service area.

### 5.3 Preliminary design .

5.3.1 Preliminary design process . During the preliminary design the configuration of the FOCT is developed to the point where interconnection box locations and trunk requirements are identified. The information determined during this phase is:

- a. Fiber function identification
- b. Fiber quantity
- c. Trunk and local cable identification
- d. Termination type
- e. Preliminary interconnection box size, configuration and location
- f. Trunk and local cable redundancy
- g. Special link performance requirements
- h. Other special requirements

5.3.1.1 Fiber function . Fibers are identified as either trunk fibers, those in trunk cables run between interconnection boxes, or local fibers, those in local cables run between end user equipment and interconnection boxes.

5.3.1.1.1 Trunk fiber categories . There are four categories of trunk fibers:

- a. Allocated and used
- b. Allocated and not used
- c. Unallocated
- d. Unused

5.3.1.1.1.1 Allocated and used (trunk) . Allocated and used fibers are fibers that are required by a user to interconnect system equipments. System specifications are reviewed to determine the fiber optic interconnection requirements. These interconnection requirements are then used to determine the number and type of allocated fibers required in the trunks between interconnection boxes. Fibers contained within this category are:

- a. Normal channel fibers (see 3.2.11)
- b. Alternate channel fibers (see 3.2.3)
- c. Non Redundant Channel (NRC) fibers (see 3.2.10)

5.3.1.1.1.2 Allocated and not used (trunk) . Allocated and not used fibers are fibers that are assigned to specific systems but are not actively used by the system equipment. Manual reconfiguration is required in order to activate the use of these fibers. Fibers in this category are:

- a. System required spare fibers
- b. FOCT supplied redundant fibers

5.3.1.1.1.3 Unallocated . Unallocated fibers are fibers included in the basic design that are not designated for use by a specific system. These fibers are:

## MIL-HDBK-2051(SH)

- a. General spare fibers (see 3.2.21)
- b. Growth fibers for future systems (as yet unidentified)

Unallocated fibers provide shipboard flexibility in recovering from random failures and battle damage, and can improve survivability and availability. In addition, when new systems or upgrades are installed on a ship already in service, some or all of the required trunk fibers may already be installed which facilitates a smoother ship upgrade process.

5.3.1.1.1.4 Unused. Unused fibers are fibers that are not required in the design, but occur within the FOCT when the required number of fibers is less than the number of fiber available within a standard cable size.

5.3.1.1.2 Local fiber categories. There are also four categories of local fibers:

- a. Allocated and used
- b. Allocated and not used
- c. Unallocated
- d. Unused

5.3.1.1.2.1 Allocated and used (local). Allocated and used fibers are the fibers required by the system to interconnect the system equipments together via the FOCP fibers. Fibers contained within this category are:

- a. Normal channel fibers (see 3.2.11)
- b. Alternate channel fibers (see 3.2.3)
- c. NRC fibers (see 3.2.10)

5.3.1.1.2.2 Allocated and not used (local). Allocated and not used fibers are system required fibers that are not actively used by the end user equipment. Manual reconfiguration is required at the end user equipment and in the interconnection box to activate use of these fibers. Fibers contained within this category are:

- a. System required spares
- b. System required redundant fibers
- c. System required growth fibers

5.3.1.1.2.3 Unallocated (local). These are required spare fibers for local cables which penetrate water tight bulkheads.

5.3.1.1.2.4 Unused (local). Unused fibers are fibers that are not required by the end user equipment, but occur within the FOCT when the required number of fibers is less than the number of fiber available within a standard cable size.

5.3.1.2 Trunk fiber quantity allocation. The number of required fibers in a trunk(s) between interconnection boxes is determined from the number of fibers required by all of the systems for each of the categories listed in 5.3.1.1. The number of trunks is affected by system routing restrictions (see 5.3.1.6 and 5.4.1.1).

5.3.1.2.1 Quantity of allocated and used fibers (trunk). The number of allocated and used trunk fibers is determined from the end user equipment drawings and ship configuration drawing. If possible, fiber for systems that are planned for installation, but not installed prior to delivery, should be included in this category.

## MIL-HDBK-2051(SH)

5.3.1.2.2 Quantity of allocated and not used fibers (trunk) . The number of allocated trunk spares should be determined from the system specification or system drawings. Redundant trunk fibers should not be provided for normal and alternate channel trunk fibers unless required by the system. In those cases where redundant local fibers are required by a system, redundant trunk fibers should also be provided to connect between the redundant local fibers. Redundant trunk fibers may be provided for NRC trunk fibers if this redundancy is judged to be beneficial by the system designer and the FOCT designer.

5.3.1.2.3 Quantity of unallocated fibers (trunk) . Growth fibers should be provided in the trunks for future users that have not as yet been identified. The quantity of growth fibers provided in a trunk should not be less than 20 percent of the total number of allocated fibers in that trunk. Spare trunk fibers should also be provided (the percentage of fibers required to be designated as spare should be found in the ship specification). Generally, the number of spare fibers required is calculated as a percentage of the number of allocated fibers. A minimum of 5 percent of the allocated and used fibers within a cable should be provided as spares.

5.3.1.3 Local fiber quantity allocation . The number and type of local fibers required for each end user equipment is determined by reviewing the system drawings. The nearest interconnection box that those fibers should be routed to is determined by reviewing the FOCT configuration drawing.

5.3.1.3.1 Quantity of allocated and used fibers (local) . The number of allocated and used local fibers is determined from the system drawings and the ship configuration drawing. Fibers for systems planned but not installed prior to ship delivery should not be included in the allocated and used local cable or fiber determination.

5.3.1.3.2 Quantity of allocated and not used fibers (local) . The number of system allocated spare fibers in local cables should be determined from the system drawings or specification. Redundant or growth local fibers or cables should not be provided unless required by the system.

5.3.1.3.3 Quantity of unallocated fibers (local) . For local cables which penetrate decks or bulkheads the number of spare fibers should be as specified in the ship specification. In this case, a minimum of 5 percent of the allocated and used fibers within a cable should be provided as spares. For all other local cables, spare fibers are generally not required.

5.3.1.4 Trunk cables . The number of trunk cables required between interconnection boxes depends on the number of trunk fibers required. There are four standard fiber counts for Navy fiber optic cable, 4, 8, 24 and 36 fibers; any of these cable sizes may be used. The following design principles should be observed when developing the trunk cable information:

- a. The number of allocated and used fibers in a trunk cable should not be greater than 75 percent of the total number of fibers in the cable.
- b. Multimode and single mode fiber should be put in separate cables (standard Navy cables do not mix the fiber types).
- c. Redundant fibers should be put in separate cables from their respective NRC fibers.
- d. Redundant cables should be routed as described in 5.3.1.6 and 5.4.1.1.

## MIL-HDBK-2051(SH)

5.3.1.5 Terminations . The type of termination used should be determined from the system drawings or specification. If there are no system requirements, either the MIL-C-83522/16 connector or the MIL-S-24623/4 splice may be used. Link loss budgets should be computed (if the system designer has not already done so) to ensure that the system link loss requirements can be met by the selected termination. The number of each type of termination should be identified in either the block diagram or as a termination requirements list. This determines which termination modules are required in the interconnection box as well as the size of the interconnection box. This also helps the shipbuilder to more accurately determine the cost of the installation.

5.3.1.6 Service areas and interconnection boxes . The size of an interconnection box is determined by the number and types of interconnections required in a service area. The Navy standard interconnection box allows two different types of interconnection modules, one for connectors and one for splices. The splice module can consist of one or two splice tray holders (each splice tray holder can house 36 splices), while the connector module can house 48 connections. The largest interconnection box available can house three interconnection modules.

5.3.1.6.1 Interconnection box growth . The interconnection box should have unused interconnection adaptors (splices or connectors) to provide for future growth. The number of unused adapters should be as specified in the ship specification. Generally, the number of unused termination spaces can be any combination of connectors or splices in interconnection boxes with both type terminations.

5.3.1.6.2 Unallocated fiber and unused fiber termination . The types of terminations (if any) required on unallocated fibers and unused fibers should be as specified in the ship specification. Typically, both unallocated fibers and unused fibers are not terminated. However, these fibers should be provided with a connector adaptor or splice tray position. These positions may be some of the unused connector adapter or splice tray positions provided for future growth.

5.3.1.6.3 Service area division . If the number of cables and terminations in a service area cannot be accommodated in a single interconnection box then that service area should be divided into separate service areas so that there is only one interconnection box in each service area. An exception to this is if the service area is a single compartment. If the number of cables and terminations in a service area cannot be accommodated in a single interconnection box then more than one interconnection box can be used. 5.4.1.3 provides guidance on the use of multiple interconnection boxes within a service area.

5.3.1.6.4 Intermediate interconnection boxes . An intermediate interconnection box is an interconnection in which two trunk cables are connected together (see figure 3). The use of intermediate interconnection boxes should be avoided. If only one or two fibers are required between two interconnection boxes and an alternate route that uses an intermediate interconnection box is available, the use of an intermediate interconnection box may be justified (see figure 4). Link loss budgets should be computed to ensure that the link through the intermediate interconnection box meets the system link loss requirements.

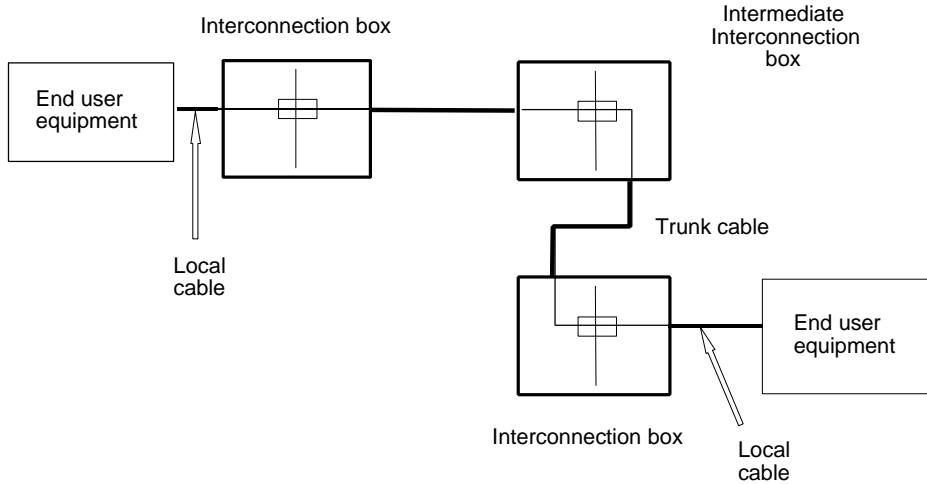

Note: This arrangement is not recommended.

**FIGURE 3. Intermediate interconnection box.**

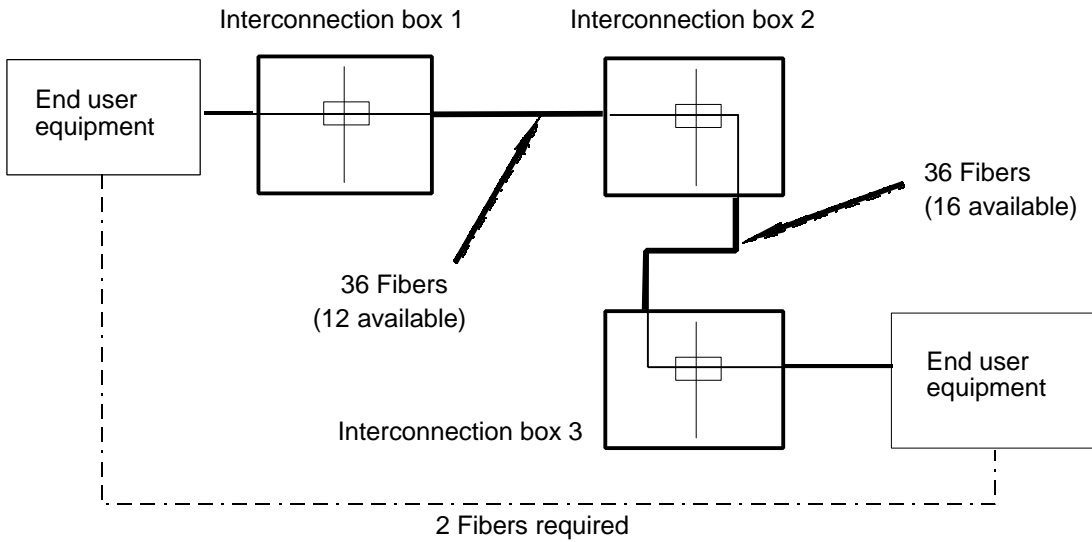

**FIGURE 4. Use of an intermediate interconnection box.**

5.3.1.7 Normal and alternate connections. For channels with both a normal and alternate connection, if the normal local cable crosses a watertight bulkhead, the alternate cable should be routed to a different interconnection box than the normal local cable (see figure 5).

## MIL-HDBK-2051(SH)

5.3.1.8 Link performance . A link loss budget should be calculated for each link in the FOCT unless the system designer has already done so. The calculations should be made as specified in MIL-STD-2052. If specific FOCT links are required to have a performance beyond that of a standard FOCT link (see MIL-STD-2042-6), these requirements and the links to which they apply should be noted. Examples of special performance requirements are requirements for the loss to be lower than the values specified in MIL-STD-2042-6 or for the total link length to be within specified bounds.

5.3.1.9 FOCT security . In general, the ship is considered a secure area and normal FOCT security should consist of the installation of fiber optic cables and interconnection boxes in any location aboard the ship. Normal interconnection box security should be provided through the bolting down of the interconnection box cover.

5.3.1.9.1 Special security requirements . Special security requirements for the FOCT should be determined from the system specifications and the ship specification. Systems with different security requirements may use the same FOCT, depending upon the specific security requirements. When the FOCT contains fibers with classified information as well as non-classified information, specific security information can be obtained from NAVSEA Code 03K21.

5.3.1.10 Local area network (LAN) survivability .

5.3.1.10.1 Distributed implementations . For FOCT links that are part of a distributed LAN implementation designed with a normal LAN and a functionally redundant alternate LAN, the following design rules are recommended.

- (1) All FOCT trunk links for the normal LAN should be survivably separated from the FOCT trunk links for the alternate LAN.
- (2) Nonadjacent FOCT trunk links for both the normal and alternate LAN should be survivably separated.

The criteria for the survivable separation of cables can be determined from section 072 of the ship specification.

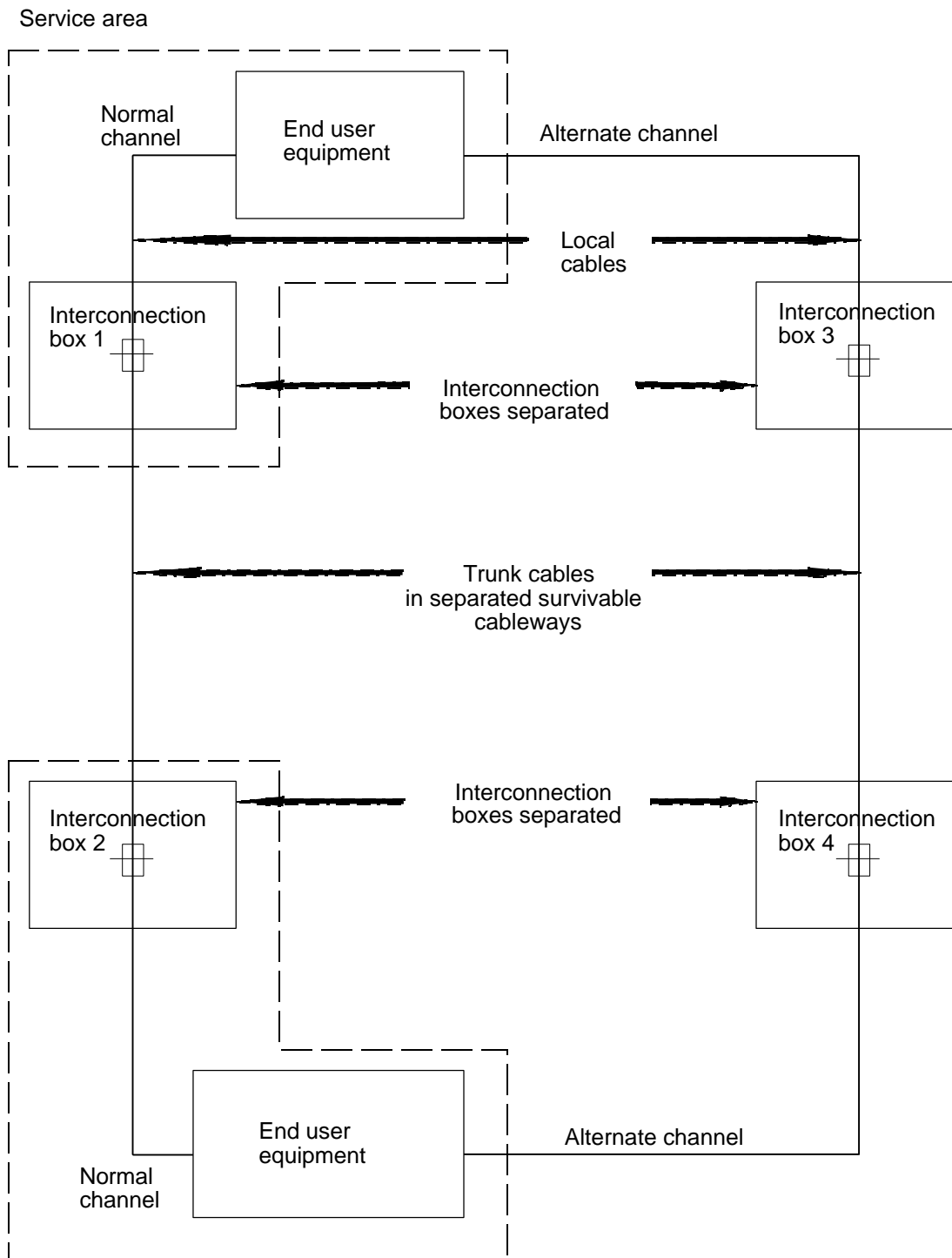

Figure 5. Local cables for normal and alternate channels.

5.3.1.10.2 Centralized implementations . For FOCT links that are part of a centralized LAN implementation designed with a normal LAN and a functionally redundant alternate LAN, the following design rules are recommended.

## MIL-HDBK-2051(SH)

- (1) All FOCT trunk links for the normal LAN should be colocated and shielded to the maximum extent possible utilizing the ship structure and armoring for protection. Likewise, all of the FOCT trunk links for the alternate LAN should be colocated and shielded to the maximum extent possible utilizing the ship structure and armoring for protection.
- (2) The FOCT trunk links for the normal LAN should be survivably separated from the FOCT trunk links for the alternate LAN.

5.3.1.11 Special requirements . Special requirements for FOCT links can be determined from the system specifications and the ship specification. Special requirements include length, loss, and routing restrictions beyond those of typical FOCT links.

5.3.2 FOCT block diagram and isometric cabling diagram . A preliminary design block diagram and isometric cabling diagram of the FOCT should be produced. The drawings should include:

- a. Interconnection box service areas
- b. Interconnection box locations (identify compartment)
- c. Trunk paths between interconnection boxes (separation requirements noted)
- d. Cable sizes and type for each trunk path
- e. Number of single mode and multimode fibers in each trunk path
- f. Number of fibers of each functional type in each trunk path
- g. Termination type for each fiber to be terminated
- h. Interconnection box sizes (1, 2 or 3 module)
- i. Type of termination modules in each interconnection box
- j. Notes on special performance requirements for any links

5.4 Detailed design . The detailed design phase is the final phase in the cable plant design process. It should be done at the same time as the ship's detailed design. The FOCT preliminary block diagram, the system specifications, and the ship specification provide the inputs to this phase. The output of this phase should be all of the documentation necessary to install the FOCT.

#### 5.4.1 Detailed design process .

5.4.1.1 Trunk cable routing . In the design, particular care must be taken when selecting trunk paths between interconnection boxes. Where redundant and respective NRC fibers or alternate and respective normal fibers are in cables installed in the fore and aft direction, they should be survivably separated in accordance with section 072 of the ship specification. Redundant and NRC fibers should come together only at the interconnection box that they service. Similarly, normal and alternate fibers should come together only at the end user equipment they support.

5.4.1.2 Local cable routing . Local cables should be routed from the end user equipment to the interconnection box for the service area containing the end user equipment. Systems which have normal and alternate channels should have the respective local cables routed to separate interconnection boxes. Local cables for normal and alternate channels should be survivably separated from each other once they are further than sixty feet from the end user equipment.

## MIL-HDBK-2051(SH)

5.4.1.3 Interconnection box configuration. The interconnection box should be configured to provide ready access to redundant and growth fibers. The connector module should be filled starting with the row closest to the inside of box and working outward (see figure 6). Normal and alternate fibers should be mounted nearest the inside of the box. NRC fibers should be mounted next. NRC fibers terminated with connectors should be mounted on a separate row with the corresponding redundant fibers mounted in the row immediately above the NRC fibers. Unused adaptors should be mounted closest to the outside of the interconnection box. For splices, the normal, alternate, NRC and redundant fibers should be separated from growth and unused splice locations (see figure 7). NRC fibers terminated with splices should be mounted in separate trays from normal and alternate channels, with the redundant fiber located immediately next to the corresponding NRC fiber (see figure 8).

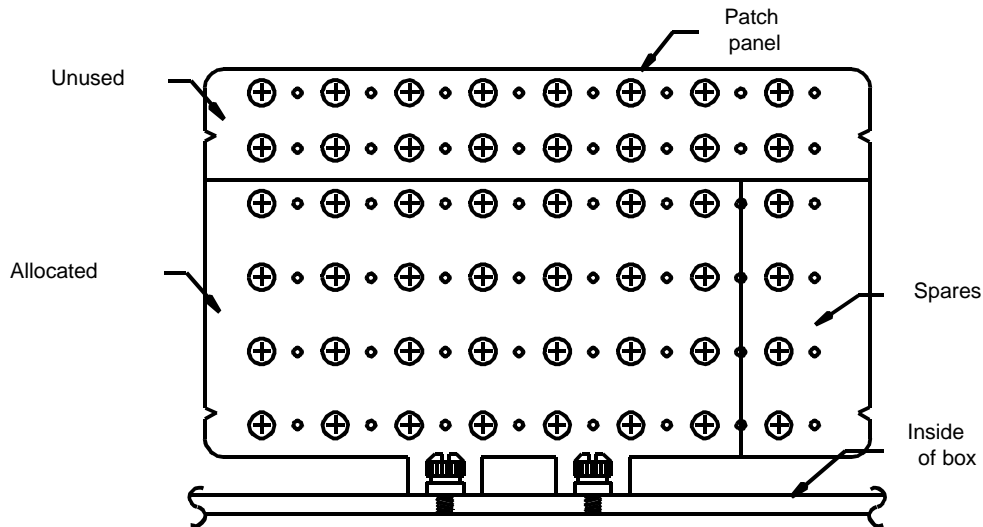

FIGURE 6. Patch panel configuration.

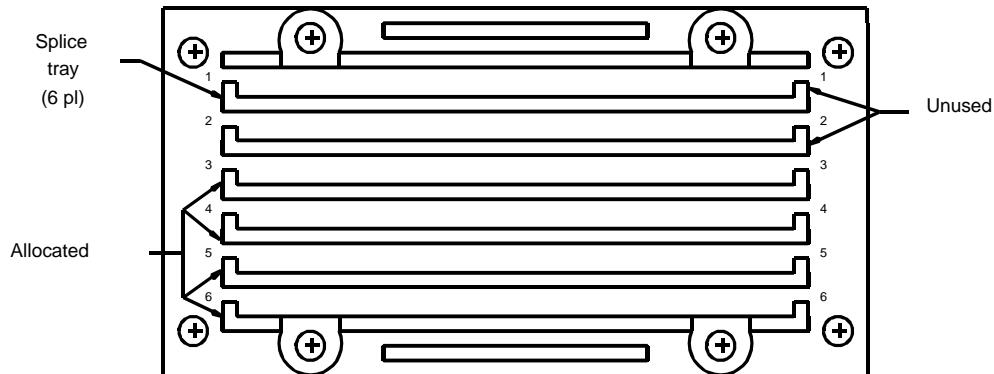
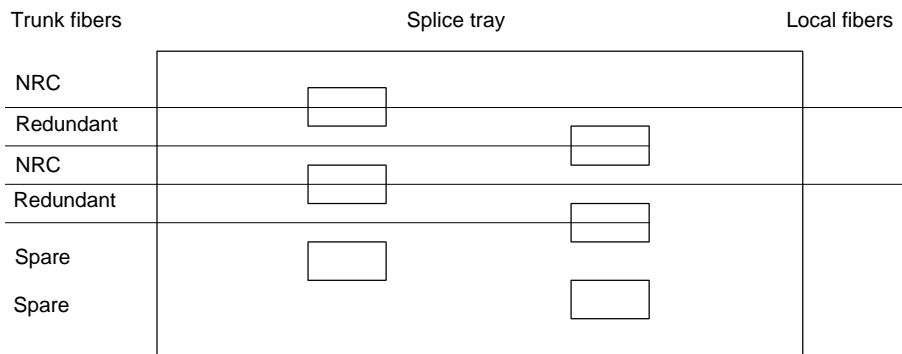

FIGURE 7. Splice tray holder configuration.

## MIL-HDBK-2051(SH)

5.4.1.3.1 Cable routing to multiple interconnection boxes in a service area. If more than one interconnection box is required in an interconnection box service area, the cables entering that area should be separated between the boxes based on the point of compartment entry. For example, cables coming from aft sections should be terminated in one interconnection box while cables from forward sections should be terminated in the other box.

5.4.1.4 Local cable end user equipment interface . The termination on the local cable that interfaces to the end user equipment should be compatible with the system equipment. Single fiber connectors can be used for this interface, however, the single fiber connectors should be mounted internally to the equipment or in an equipment rack. Single fiber connectors should not be mounted externally to the equipment. Multifiber connectors can also be used for this interface. Figures 9 and 10 show typical local cable end user equipment terminations.



(a) NRC and redundant fibers

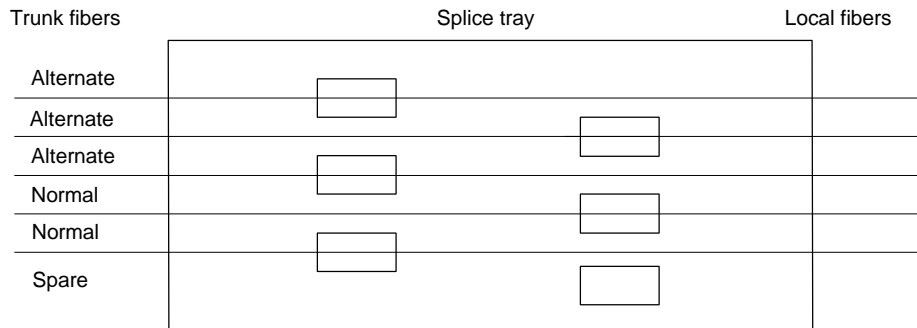

(b) Normal and alternate fibers

**Figure 8. Splice tray configuration.**

MIL-HDBK-2051(SH)

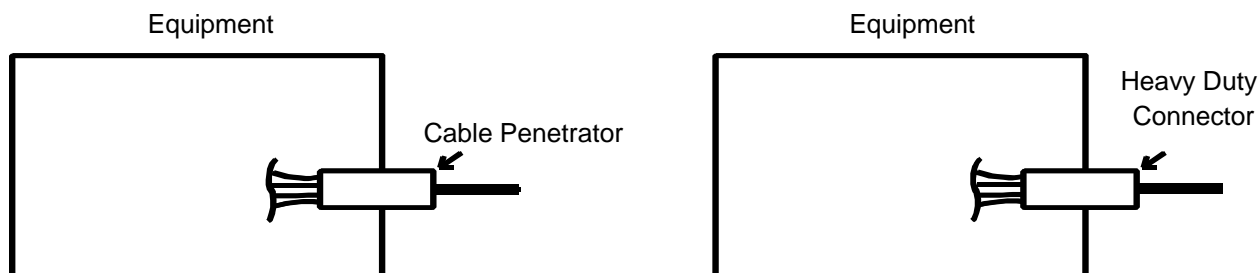
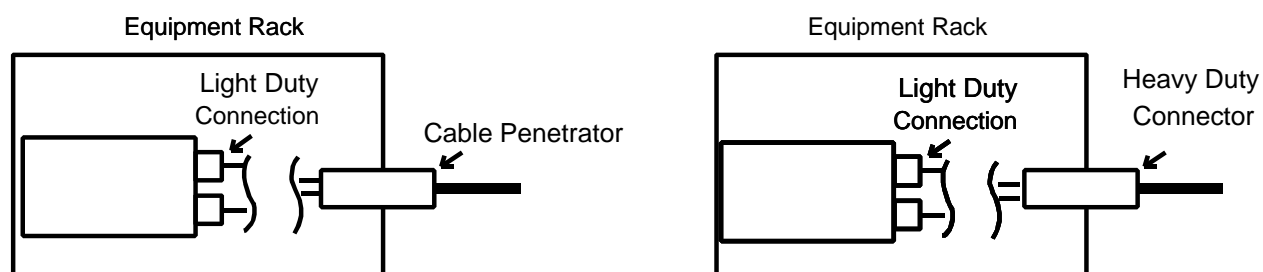
Figure 9. Typical end user equipment terminations.Figure 10. Typical end user equipment rack terminations.

5.4.1.5 Fiber optic components . Standard Navy fiber optic components should be used in the FOCT. The ship specification should provide a list of fiber optic components approved for use in that ship. If there are questions on the use of a particular component, NAVSEA 03K12 should be contacted for information. The following sections summarize the standard fiber optic components that are available for use in the FOCT.

5.4.1.5.1 Fiber type . There are two basic types of fiber that are qualified for shipboard use, single mode and multimode. The type of fiber installed in the FOCT should be determined from the system requirements. The Navy standard multimode fiber is the MIL-F-49291/6 fiber (62.5  $\mu\text{m}$  core/125  $\mu\text{m}$  cladding diameters). The Navy standard single mode fiber is the MIL-F-49291/7 fiber (9  $\mu\text{m}$  nominal mode field diameter).

5.4.1.5.2 Fiber optic cables . The Navy standard fiber optic cables are the MIL-C-85045 cables. Either of the two standard fibers can be used in the Navy standard cables. There are four standard fiber counts that can be used, 4, 8, 24 and 36 fiber. Single mode and multimode fibers are not contained in the same cable.

## MIL-HDBK-2051(SH)

5.4.1.5.3 Single fiber terminations . There are two Navy standard terminations that can be used, MIL-C-83522/16 (ST style) connectors and MIL-S-24623/4 (rotary mechanical) splices. The type of termination used on the trunk and local fibers should be determined from the system specification or system drawings. If there is no specific requirement for a termination type, either type may be used if the system link loss budget can be met using the selected termination type. The MIL-C-83522/16 connector and the MIL-S-24623/4 splice should not be installed externally to equipment or enclosures.

5.4.1.5.4 Multifiber terminations . The multifiber termination is used for direct connection of local cables to the system equipment. The termination on the local cable should be compatible with and mate with the connector on the end user equipment. The Navy standard MIL-C-28876 multifiber connector should be used for all multifiber terminations. Navy approved MIL-T-29504/14 terminations should be used within the MIL-C-28876 connector.

5.4.1.5.5 Interconnection boxes . The Navy standard MIL-I-24728 interconnection box should be used.

5.4.1.6 Installation and test . The FOCT should be installed and tested in accordance with MIL-STD-2042.

5.4.2 Detailed design documentation . The output of the detailed design phase is the documentation necessary to install the FOCT. This documentation includes:

- Fiber run lists (or CIIDS)
- Cable pull charts
- Interconnection box configuration drawings
- Detailed parts lists
- Cable block diagrams

5.4.2.1 Fiber run lists . The fiber run list should provide the end-to-end connections for each fiber. Each fiber should be designated by a unique fiber number and have the appropriate system identification included in the fiber run list. The fibers should be numbered in accordance with the ship specification. The fiber function (normal, alternate, NRC, redundant, spare, or growth) should also be identified on the fiber run list. This information may be included on the FOCT design configuration and interconnection box configuration drawings rather than as a separate fiber run list.

5.4.2.2 Cable pull charts . The cable pull chart should provide the detailed routing information for each cable. Each cable should be designated by a unique cable number. The cables should be numbered in accordance with ship specification.

5.4.2.3 Interconnection box configuration drawings . Interconnection box configuration drawings should identify the interconnect requirements between local and trunk fibers. The type of termination for each fiber and the location of that termination should be identified.

5.4.2.4 Detailed parts list . A detailed parts list should be generated identifying all of the components required. The list should include the Navy standard specification and quantity required for each type of component identified in the cable FOCT detail design.

MIL-HDBK-2051(SH)

6. NOTES

6.1 Intended use . The focus of the design process and guidelines is new ship construction and class upgrades. Those categories of ship programs are most amenable to the incorporation of a FOCT. However, the design guidelines can be effectively applied to ship overhaul and backfit programs.

6.2 Subject term (key word) listing .

Allocated fiber  
Alternate channel  
Naval platform  
Normal channel  
Spare fiber  
Unallocated fiber

Preparing activity:  
NAVY - SH  
(Project GDRQ-N165)

# STANDARDIZATION DOCUMENT IMPROVEMENT PROPOSAL

## INSTRUCTIONS

1. The preparing activity must complete blocks 1, 2, 3, and 8. In block 1, both the document number and revision letter should be given.
2. The submitter of this form must complete blocks 4, 5, 6, and 7.
3. The preparing activity must provide a reply within 30 days from receipt of the form.

NOTE: This form may not be used to request copies of documents, nor to request waivers, or clarification of requirements on current contracts. Comments submitted on this form do not constitute or imply authorization to waive any portion of the referenced document(s) or to amend contractual requirements.

<b>I RECOMMEND A CHANGE:</b>	1. DOCUMENT NUMBER MIL-HDBK-2051 (SH)	2. DOCUMENT DATE (YYMMDD) 22 MAY 1996
3. DOCUMENT TITLE FIBER OPTIC SHIPBOARD CABLE TOPOLOGY DESIGN GUIDANCE		
4. NATURE OF CHANGE <i>(Identify paragraph number and include proposed rewrite, if possible. Attach extra sheets as needed.)</i>		
5. REASON FOR RECOMMENDATION		
6. SUBMITTER		
a. NAME <i>(Last, First, Middle Initial)</i>	b. ORGANIZATION	
c. ADDRESS <i>(Include Zip Code)</i>	d. TELEPHONE <i>(Include Area Code)</i> (1) Commercial (2) AUTOVON <i>(If applicable)</i>	7. DATE SUBMITTED (YYMMDD)
8. PREPARING ACTIVITY		
a. NAME NAVAL SEA SYSTEMS COMMAND (SEA) 2531 JEFFERSON DAVIS HWY ARLINGTON, VA 22242-5160	b. TELEPHONE <i>(Include Area Code)</i> (1) Commercial (2) AUTOVON	
c. ADDRESS <i>(Include Zip Code)</i>	IF YOU DO NOT RECEIVE A REPLY WITHIN 45 DAYS, CONTACT: Defense Quality and Standardization Office 5203 Leesburg Pike, Suite 1403, Falls Church, VA 22041-3466 Telephone (703) 756-2340 AUTOVON 289-2340	